

# SPECIFICATION

受 控

Customer : RADIOTECH

Applied To :

Product Name : Magnetic Buzzer

Model Name : KPX-G1205A-K9795



Drawing No. : OEM9795R

Compliance with RoHS(本品符合ROHS指令)

Signature of Approval

--

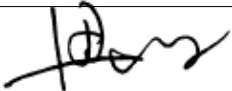
Signature of KEPO

Approved by	Checked by	Issued by	Date
			

宁波凯普电子有限公司



Ningbo Kepo Electronics Co.,Ltd.

宁波东钱湖镇东钱湖工业区宝源路 25 号

TEL:+86-574-88370330 FAX:+86-574-88370329

No.25 Baoyuan road Dongqian Lake, Industry Area, Dongqian town,Ningbo City,  
China(Post Code:315121)

[Sales@chinaacoustic.com](mailto:Sales@chinaacoustic.com)

[www.chinaacoustic.com](http://www.chinaacoustic.com)

Specification for Magnetic Buzzer		Page	2/10
Model No. :                    KPX-G1205A-K9795		Revision No.	1.0
		Drawing No.	OEM9795R

## CONTENTS

1. Scope  
范围
2. General  
概要
3. Electrical and Acoustic Characteristics.  
电声参数
4. Reliability Test  
可靠性试验
5. Measurement Block Diagram & Response curve  
测试图和曲线图
6. Structure  
结构
7. Dimensions  
尺寸
8. Packing  
包装
9. Revision  
履历表

Specification for Magnetic Buzzer		Page	3/10
		Revision No.	1.0
Model No. :	KPX-G1205A-K9795	Drawing No.	OEM9795R

## 1. Scope

This product specification is applied to the Magnetic Buzzer in alarm systems. Please contact us when using this product for any other applications than described in the above.

本规格书适用于电磁式蜂鸣器，通常它用在系统中做报警或提示的蜂鸣器用，如果将该产品用于其它领域，请与我们联系。

## 2. General

- 2.1 Out-Diameter : Ø12 mm  
 外径: Ø12 mm
- 2.2 Height : 9.5 mm  
 高度: 9.5 mm
- 2.3 Weight : 2 g  
 重量: 2克
- 2.4 Operating Temperature range:  
 -40~+85°C without loss of function  
 工作温度: -40~+85°C
- Store Temperature range:  
 -40~+85°C without loss of function  
 储藏温度: -40~+85°C

## 3. Electrical and Acoustic Characteristics.

Test condition : 15 ~ 35 °C, 25% ~ 85% RH, 860~1060 mbar  
 测试条件: 15~35 °C, 25%~85%RH, 860~1060mbar

	Items 项目	Specification 规格
1	Rated Voltage 额定电压	5VDC
2	Operating Voltage 工作电压	4~8VDC
3	Max.Rated Current 额定电流	30mA/5VDC
4	Resonant Frequency 谐振频率	2.3± 0.3KHz
5	Min.Sound Pressure Level 额定声压	85dB/5VDC/10cm
6	Tone Nature 音调	Continuous (直音)
7	Case Material/Color 壳体材质/颜色	PBT/BLACK

Specification for Magnetic Buzzer		Page	4/10
		Revision No.	1.0
Model No. :	KPX-G1205A-K9795	Drawing No.	OEM9795R

## 4. Reliability Test

After test(1~7item), the Buzzer S.P.L . difference shall be within  $\pm 10\text{dB}$ , Frequency difference shall be within  $\pm 0.5\text{KHz}$ . and the appearance not exist any change to be harmful to normal operation(e.g. cracks,rusts,damages and especially distortion).

在1-7项试验后，蜂鸣器的声压变化值在 $\pm 10\text{dB}$ 之内，频率变化在 $\pm 0.5\text{KHz}$ 之内。外观无变化（例如：开裂、生锈、损伤、变形等现象）。

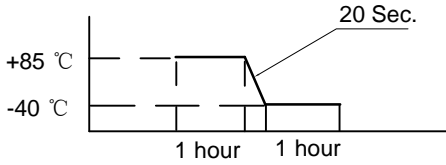
1	High Temperature Test 高温试验	<p>After being placed in a chamber with <math>+85\pm 2^\circ\text{C}</math> for 240 hours and then being placed in natural condition for 2 hours, sounder shall be measured.</p> <p>放置于温度<math>+85\pm 2^\circ\text{C}</math>的烘箱内240小时，然后取出，在常温下放置2小时后，测试声响器。</p>
2	Low Temperature Test 低温试验	<p>After being placed in a chamber with <math>-40\pm 2^\circ\text{C}</math> for 240 hours and then being placed in natural condition for 2 hours, sounder shall be measured.</p> <p>放置于温度<math>-40\pm 2^\circ\text{C}</math>的制冷箱内240小时，然后取出，在常温下放置2小时后，测试声响器</p>
3	Humidity Test 潮湿试验	<p>After being placed in a chamber with 90 to 95%R.H. at <math>+60\pm 2^\circ\text{C}</math> for 240 h and then being placed in natural condition for 2h , sounder shall be measured.</p> <p>将产品置于湿度为 90~95%R.H，温度为<math>60\pm 2^\circ\text{C}</math>试验箱中240小时，然后在正常大气压条件下恢复2小时后，进行测量</p>
4	Thermal Shock Test 热冲击试验	<p>After being worked in a chamber at <math>+85\pm 2^\circ\text{C}</math> for 1 hour, then sounder shall be placed in a chamber at <math>-40\pm 2^\circ\text{C}</math> for 1 hour(1 cycle is the below diagram).</p> <p>After 10 above cycles, sounder shall be measured after being placed in natural condition for 1 hour.</p> <p>将产品置于<math>85\pm 2^\circ\text{C}</math>试验箱中，先工作1小时，然后将产品置于<math>-40\pm 2^\circ\text{C}</math>试验箱中，再工作1小时，经过10个循环后，在正常大气压条件下恢复1小时，进行测量</p> 

Specification for Magnetic Buzzer		Page	5/10
		Revision No.	1.0
Model No. :	KPX-G1205A-K9795	Drawing No.	OEM9795R

#### 4. Reliability Test

	Item	Specification
5	Vibration Resistance 振动试验	<p>Sounder shall be measured after being applied vibration of amplitude of 1.5mm with 10 to 30Hz band of vibration frequency to each of 3 perpendicular directions for 2 hour.</p> <p>振幅为1.5mm，频率为10~30Hz，三个不同轴方向各振动2小时，试验后进行测量。</p>
6	Drop Test 跌落试验	<p>Sounder packed in the carton are dropped in six direction from the height of 80cm to the concrete floor.</p> <p>跌落高度80cm,6个不同方向整箱跌落到水泥地，试验后进行测量。</p>
7	Solderability 可焊性试验	<p>Lead terminals are immersed in rosin for 5 seconds and then immersed in solder bath of <math>+260\pm 5^{\circ}</math> C for <math>3\pm 0.5</math> seconds.</p> <p>插针浸入松香5秒，然后再浸入<math>+260\pm 5^{\circ}</math> C的锡炉中<math>3\pm 0.5</math>秒，插针表面应覆盖一层光滑明亮的焊料。</p>
8	Terminal Strength Pulling 插针强度试验	<p>The force 10 seconds of 9.8N is applied go each terminal in axial direction.</p> <p>插针应承受9.8N拉力，拉力时间10秒，插针无松动和脱落等现象。</p>
9	连续运行 continuum run	<p>5VDC/240小时</p> <p>5VCD//240hours</p>

Specification for Magnetic Buzzer		Page	6/10
		Revision No.	1.0
Model No. :	KPX-G1205A-K9795	Drawing No.	OEM9795R

## 5. Measurement Block Diagram & Response curve

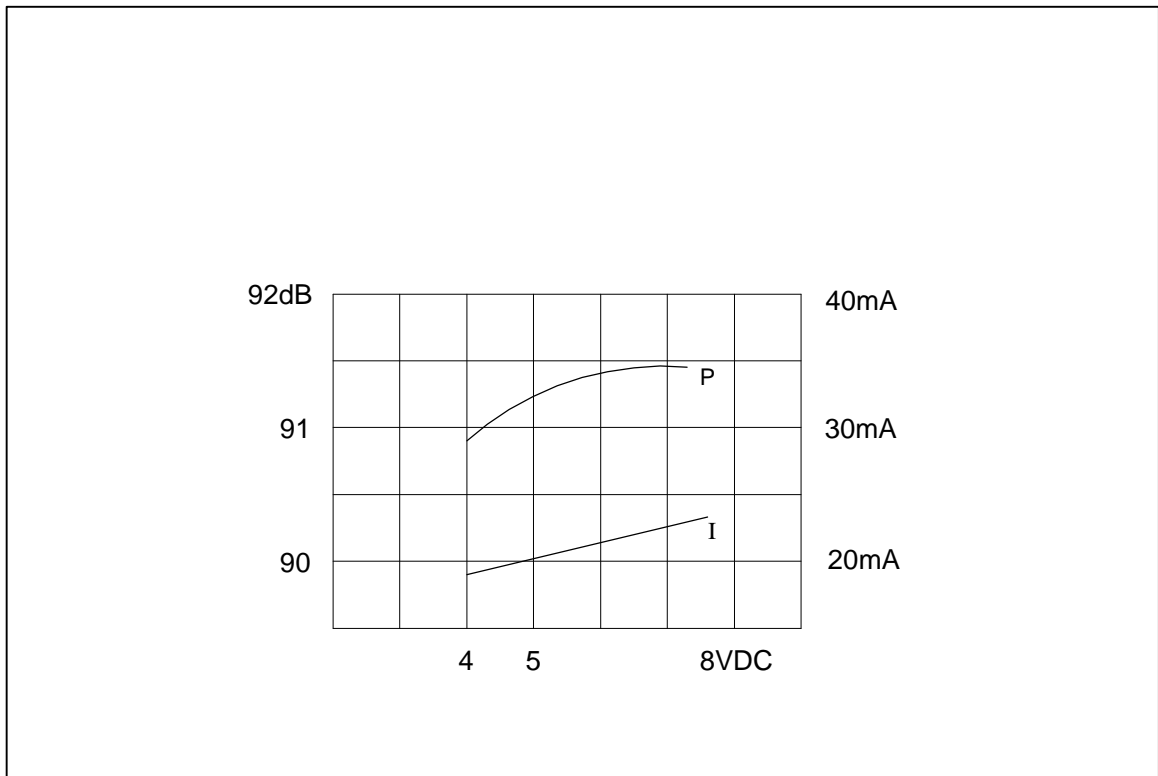
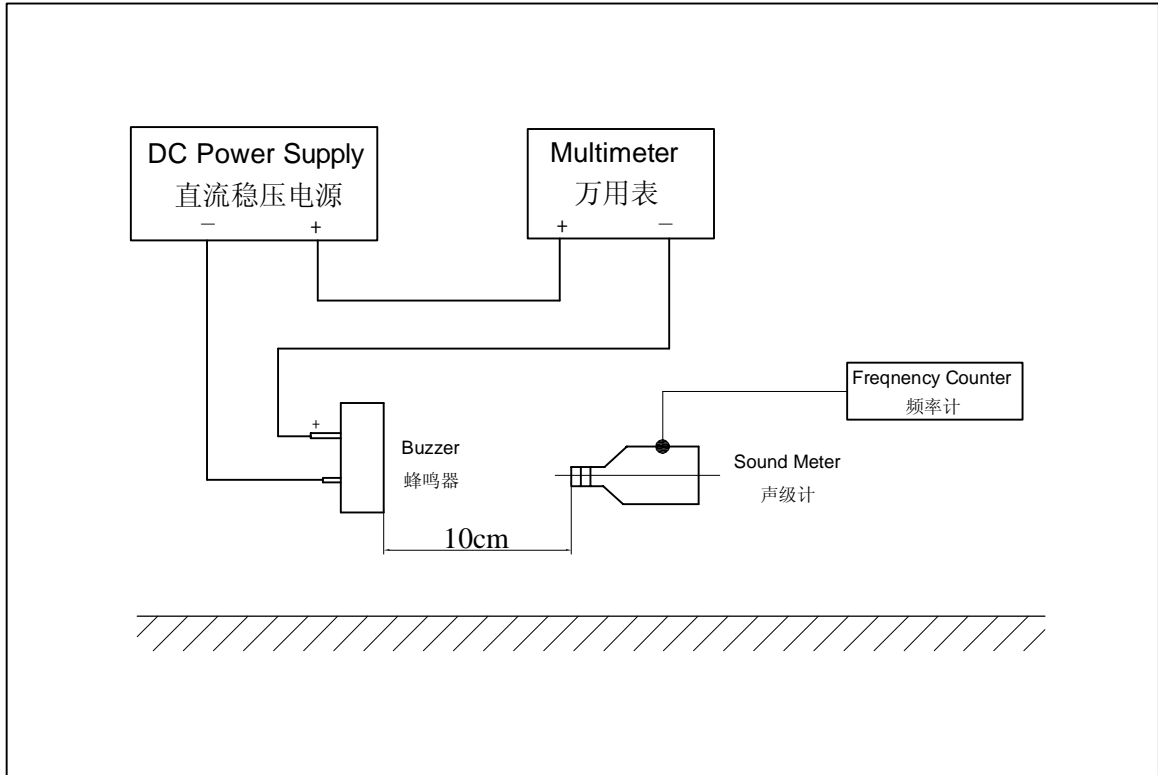

Specification for Magnetic Buzzer		Page	7/10
		Revision No.	1.0
Model No. :	KPX-G1205A-K9795	Drawing No.	OEM9795R

## 6. Structure



6	Case 壳体	1	PBT	
5	T Core T 铁	1	Fe	
4	Coil 线圈	1	QANR	
3	Magnetic ring 磁环	1	/	
2	PCB with pin 带导针印制板	1	/	
1	Diaphragm 膜片	1	/	
No.	Part Name 型号	Q'TY	Material 材质	SGS 编号

Model No. :                    KPX-G1205A-K9795	Page	8/10
	Revision No.	1.0
	Drawing No.	OEM9795R

## 7. Dimensions

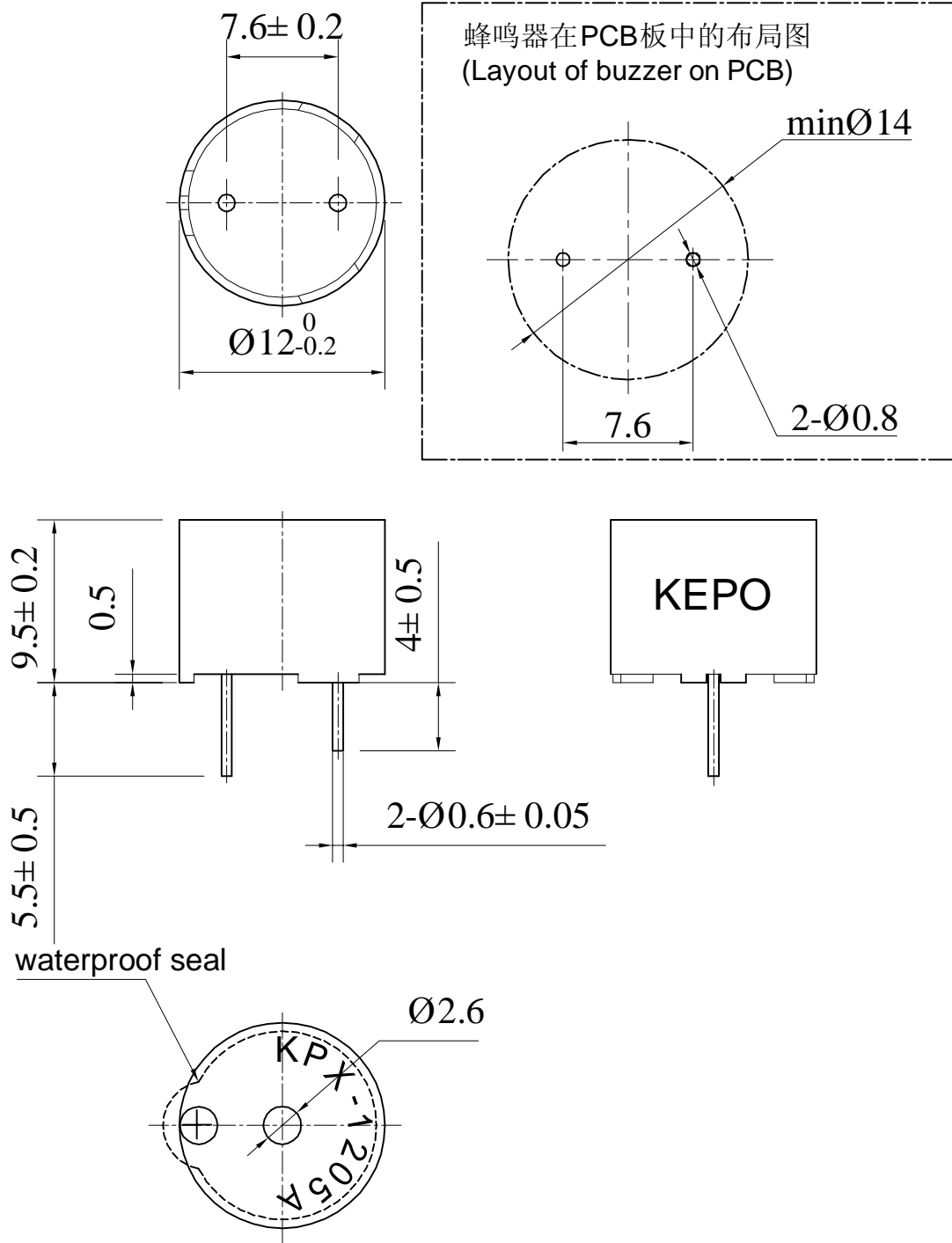

FIRST ANGLE PROJECTION

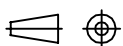

UNIT : mm  
Tolerance :  $\pm 0.5$



Specification for Magnetic Buzzer		Page	9/10
		Revision No.	1.0
Model No. :	KPX-G1205A-K9795	Drawing No.	OEM9795R

8. Packing



QTY: 100Pcs



QTY: 500Pcs



QTY: 6000Pcs

425x400x315mm

Specification for Magnetic Buzzer		Page	10/10
Model No. : KPX-G1205A-K9795		Revision No.	1.0
		Drawing No.	OEM9795R

## 9. Revision

Rev. No.	DATE	PAGE	DESCRIPTION	SIGN
1.0	2013.07.05	10	primary	