

# 2-BIT BIDIRECTIONAL 1MHz, I<sup>2</sup>C BUS AND SMBUS VOLTAGE-LEVEL TRANSLATOR WITH 8kV HBM ESD

 Check for Samples: [TCA9406](#)

## FEATURES

- 2-Bit Bidirectional Translator for SDA and SCL Lines in Mixed-Mode I<sup>2</sup>C Applications
- 5.5-V Tolerant OE Input
- Level Translation Range
  - 1.8 V to 2.5 V/3.3 V/5 V
  - 2.5 V to 2.5 V/3.3 V/5 V
  - 3.3 V to 3.3 V/5 V
- Internal 10-kΩ Pullup Resistor on Each Port and Option to Add External Pullup Resistor if Required
- Provides Bidirectional Voltage Translation With No Direction Pin
- I<sub>off</sub> Support Partial Power Down (V<sub>CC</sub>= 0 V) With 2 mA
- High-Impedance Output SCL1, SDA1, SCL2, and SDA2 Pins When OE = Low or V<sub>CC</sub>= 0 V
- Latch-Up Performance Exceeds 100 mA Per JESD 78, Class II
- ESD Protection Exceeds JESD 22
  - A Port
    - 2500-V Human-Body Model (A114-B)
    - 250-V Machine Model (A115-A)
    - 1500-V Charged-Device Model (C101)
  - B Port
    - 8-kV Human-Body Model (A114-B)
    - 250-V Machine Model (A115-A)
    - 1500-V Charged-Device Model (C101)

## TYPICAL LEVEL-SHIFTER APPLICATIONS

- I<sup>2</sup>C/SMBus
- UART
- GPIO

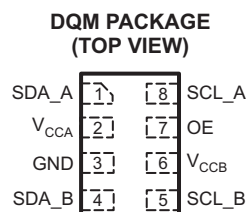
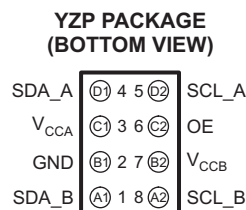
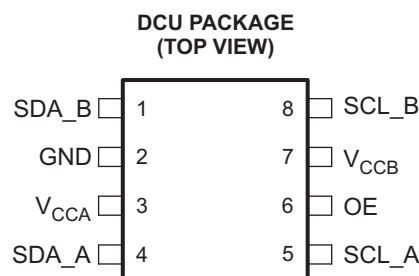

## DESCRIPTION

The TCA9406 is a dual bidirectional I<sup>2</sup>C-Bus and SMBus Voltage-Level translator with enable (OE) Input. It is operational from 1.65 V to 3.6 V on A-Port and 2.3 V to 5.5 V on B-port. The Output Enable (OE) input is referenced to V<sub>CCA</sub>, but is 5.5V tolerant

The device can also be used as a general purpose level-translator, supporting push-pull driving of the A and B ports. When driven with push-pull devices on both sides the TCA9406 can support up to 24Mbps.

Under normal I<sup>2</sup>C and SMBus operation or other open drain configurations, the device can support up to 2Mbps. It is compatible with a standard I<sup>2</sup>C bus 100 kHz, 400 kHz and 1 MHz at both sides of A-Port and B-Port.

The TCA9406 features internal 10kOHM pullup resistors. Additional external pullup resistors can be added to the bus to reduce total pullup resistance.



Please be aware that an important notice concerning availability, standard warranty, and use in critical applications of Texas Instruments semiconductor products and disclaimers thereto appears at the end of this data sheet.

The TCA9406 is not a bus buffer like the PCA9515B and PCA9517. The OE feature can be utilized to isolate one side of the bus from the other by placing both sides into a high impedance state.

The Enable (OE) should be tied to GND through a pull-down resistor to ensure the high-impedance state during power up or power down. The minimum value of the resistor is determined by the current-sourcing capability of the driver.

### ORDERING INFORMATION

For package and ordering information, see the Package Option Addendum at the end of this document.

### PIN DESCRIPTION

| NO.      |     | NAME      | TYPE  | FUNCTION  |
|----------|-----|-----------|-------|---|
| DQM, DCU | YZP |           |       |   |
| 1        | A1  | SDA_B     | I/O   | Input/output B. Referenced to $V_{CCB}$ . Allow I2C_SDA configured to 2.5V/3.3V/5V  |
| 2        | B1  | GND       | GND   | Ground  |
| 3        | C1  | $V_{CCA}$ | PWR   | A-port supply voltage. $1.65\text{ V} \leq V_{CCA} \leq 3.6\text{ V}$ and $V_{CCA} \leq V_{CCB}$ . Configuration for SDA_A, SCL_A, and OE |
| 4        | D1  | SDA_A     | I/O   | Input/output A. Referenced to $V_{CCA}$ . Allows I2C_SDA configured to 1.8V, 2.5V, 3.3V   |
| 5        | D2  | SCL_A     | I/O   | Input/output A. Referenced to $V_{CCA}$ . Allows I2C_SCL configured to 1.8V, 2.5V, 3.3V   |
| 6        | C2  | OE        | Input | Output enable (active High). Referenced to $V_{CCA}$ . Pull OE to LOW to place all outputs in tri-state mode.                             |
| 7        | B2  | $V_{CCB}$ | PWR   | B-port supply voltage. $2.3\text{ V} \leq V_{CCB} \leq 5.5\text{ V}$ for SDA_B, SCL_B   |
| 8        | A2  | SCL_B     | I/O   | Input/output B. Referenced to $V_{CCB}$ . Allow I2C_SCL configured to 2.5V/3.3V/5V  |

### TYPICAL OPERATING CIRCUIT

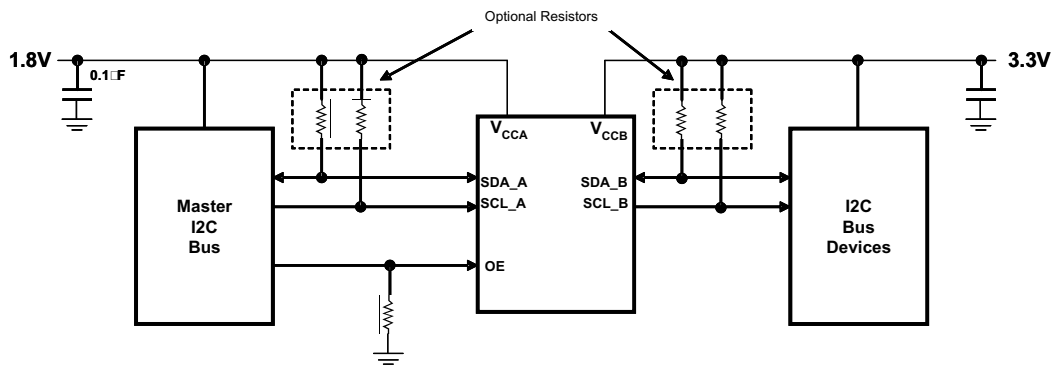

**Design Notes:**  
OE can be tied directly to 1.8V ( $V_{CCA}$ ) to always be in ENABLE mode.

## ABSOLUTE MAXIMUM RATINGS<sup>(1)</sup>

over recommended operating free-air temperature range (unless otherwise noted)

|                  |   |                    | MIN  | MAX                    | UNIT |
|------------------|---|--------------------|------|------------------------|------|
| V <sub>CCA</sub> | Supply voltage range  |                    | -0.5 | 4.6                    | V    |
| V <sub>CCB</sub> | Supply voltage range  |                    | -0.5 | 6.5                    | V    |
| V <sub>I</sub>   | Input voltage range <sup>(2)</sup>  | A port             | -0.5 | 4.6                    | V    |
|                  |   | B port             | -0.5 | 6.5                    |      |
|                  |   | OE input           | -0.5 | 6.5                    |      |
| V <sub>O</sub>   | Voltage range applied to any output in the high-impedance or power-off state <sup>(2)</sup> | A port             | -0.5 | 4.6                    | V    |
|                  |   | B port             | -0.5 | 6.5                    |      |
| V <sub>O</sub>   | Voltage range applied to any output in the high or low state <sup>(2) (3)</sup>             | A port             | -0.5 | V <sub>CCA</sub> + 0.5 | V    |
|                  |   | B port             | -0.5 | V <sub>CCB</sub> + 0.5 |      |
| I <sub>IK</sub>  | Input clamp current   | V <sub>I</sub> < 0 |      | -50                    | mA   |
| I <sub>OK</sub>  | Output clamp current  | V <sub>O</sub> < 0 |      | -50                    | mA   |
| I <sub>O</sub>   | Continuous output current   |                    |      | ±50                    | mA   |
|                  | Continuous current through V <sub>CCA</sub> , V <sub>CCB</sub> , or GND                     |                    |      | ±100                   | mA   |
| θ <sub>JA</sub>  | Package thermal impedance <sup>(4)</sup>  | DQM package        |      | 220                    | °C/W |
|                  |   | DCU package        |      | 227                    |      |
|                  |   | YZP package        |      | 102                    |      |
| T <sub>stg</sub> | Storage temperature range   |                    | -65  | 150                    | °C   |

- Stresses beyond those listed under "absolute maximum ratings" may cause permanent damage to the device. These are stress ratings only, and functional operation of the device at these or any other conditions beyond those indicated under "recommended operating conditions" is not implied. Exposure to absolute-maximum-rated conditions for extended periods may affect device reliability.
- The input and output negative-voltage ratings may be exceeded if the input and output current ratings are observed.
- The value of V<sub>CCA</sub> and V<sub>CCB</sub> are provided in the recommended operating conditions table.
- The package thermal impedance is calculated in accordance with JESD 51-7.

## RECOMMENDED OPERATING CONDITIONS<sup>(1) (2)</sup>

|                                |                                    |                                | V <sub>CCA</sub>        | V <sub>CCB</sub> | MIN                    | MAX                     | UNIT |
|--------------------------------|------------------------------------|--------------------------------|-------------------------|------------------|------------------------|-------------------------|------|
| V <sub>CCA</sub>               | Supply voltage <sup>(3)</sup>      |                                |                         |                  | 1.65                   | 3.6                     | V    |
| V <sub>CCB</sub>               | Supply voltage                     |                                |                         |                  | 2.3                    | 5.5                     | V    |
| V <sub>IH</sub>                | High-level input voltage           | A-port I/Os                    | 1.65 V to 1.95 V        | 2.3 V to 5.5 V   | V <sub>CCI</sub> - 0.2 | V <sub>CCI</sub>        | V    |
|                                |                                    |                                | 2.3 V to 3.6 V          |                  | V <sub>CCI</sub> - 0.4 | V <sub>CCI</sub>        |      |
|                                |                                    | B-port I/Os                    | 1.65 V to 3.6 V         | 2.3 V to 5.5 V   | V <sub>CCI</sub> - 0.4 | V <sub>CCI</sub>        |      |
| OE input                       |                                    |                                | V <sub>CCA</sub> × 0.65 |                  | 5.5                    |                         |      |
| V <sub>IL</sub> <sup>(4)</sup> | Low-level input voltage            | A-port I/Os                    | 1.65 V to 3.6 V         | 2.3 V to 5.5 V   | 0                      | 0.15                    | V    |
|                                |                                    | B-port I/Os                    |                         |                  | 0                      | 0.15                    |      |
|                                |                                    | OE input                       |                         |                  | 0                      | V <sub>CCA</sub> × 0.35 |      |
| Δt/Δv                          | Input transition rise or fall rate | A-port I/Os, push-pull driving | 1.65 V to 3.6 V         | 2.3 V to 5.5 V   |                        | 10                      | ns/V |
|                                |                                    | B-port I/Os, push-pull driving |                         |                  |                        | 10                      |      |
|                                |                                    | Control input                  |                         |                  |                        | 10                      |      |
| T <sub>A</sub>                 | Operating free-air temperature     |                                |                         |                  | -40                    | 85                      | °C   |

- V<sub>CCI</sub> is the supply voltage associated with the input port.
- V<sub>CCO</sub> is the supply voltage associated with the output port.
- V<sub>CCA</sub> must be less than or equal to V<sub>CCB</sub>, and V<sub>CCA</sub> must not exceed 3.6 V.
- The maximum V<sub>IL</sub> value is provided to ensure that a valid V<sub>OL</sub> is maintained. The V<sub>OL</sub> value is V<sub>IL</sub> plus the voltage drop across the pass-gate transistor.

**ELECTRICAL CHARACTERISTICS**<sup>(1) (2) (3)</sup>

over recommended operating free-air temperature range (unless otherwise noted)

| PARAMETER                           | TEST CONDITIONS   | V <sub>CCA</sub>           | V <sub>CCB</sub> | T <sub>A</sub> = 25°C |     |     | –40°C to 85°C           |     | UNIT |
|-------------------------------------|---|----------------------------|------------------|-----------------------|-----|-----|-------------------------|-----|------|
|                                     |   |                            |                  | MIN                   | TYP | MAX | MIN                     | MAX |      |
| V <sub>OHA</sub>                    | I <sub>OH</sub> = –20 μA,<br>V <sub>IB</sub> ≥ V <sub>CCB</sub> – 0.4 V | 1.65 V to 3.6 V            | 2.3 V to 5.5 V   |                       |     |     | V <sub>CCA</sub> × 0.67 |     | V    |
| V <sub>OLA</sub>                    | I <sub>OL</sub> = 1 mA,<br>V <sub>IB</sub> ≤ 0.15 V                     | 1.65 V to 3.6 V            | 2.3 V to 5.5 V   |                       |     |     | 0.4                     |     | V    |
| V <sub>OHB</sub>                    | I <sub>OH</sub> = –20 μA,<br>V <sub>IA</sub> ≥ V <sub>CCA</sub> – 0.2 V | 1.65 V to 3.6 V            | 2.3 V to 5.5 V   |                       |     |     | V <sub>CCB</sub> × 0.67 |     | V    |
| V <sub>OLB</sub>                    | I <sub>OL</sub> = 1 mA,<br>V <sub>IA</sub> ≤ 0.15 V                     | 1.65 V to 3.6 V            | 2.3 V to 5.5 V   |                       |     |     | 0.4                     |     | V    |
| I <sub>I</sub>                      | OE  | 1.65 V to 3.6 V            | 2.3 V to 5.5 V   |                       |     | ±1  | ±2                      |     | μA   |
| I <sub>off</sub>                    | A port  | 0 V                        | 0 to 5.5 V       |                       |     | ±1  | ±2                      |     | μA   |
|                                     | B port  | 0 to 3.6 V                 | 0 V              |                       |     | ±1  | ±2                      |     | μA   |
| I <sub>OZ</sub>                     | A or B port   | 1.65 V to 3.6 V            | 2.3 V to 5.5 V   |                       |     | ±1  | ±2                      |     | μA   |
| I <sub>CCA</sub>                    | V <sub>I</sub> = V <sub>O</sub> = open,<br>I <sub>O</sub> = 0           | 1.65 V to V <sub>CCB</sub> | 2.3 V to 5.5 V   |                       |     |     | 2.4                     |     | μA   |
|                                     |   | 3.6 V                      | 0 V              |                       |     |     | 2.2                     |     |      |
|                                     |   | 0 V                        | 5.5 V            |                       |     |     | –1                      |     |      |
| I <sub>CCB</sub>                    | V <sub>I</sub> = V <sub>O</sub> = open,<br>I <sub>O</sub> = 0           | 1.65 V to V <sub>CCB</sub> | 2.3 V to 5.5 V   |                       |     |     | 12                      |     | μA   |
|                                     |   | 3.6 V                      | 0 V              |                       |     |     | –1                      |     |      |
|                                     |   | 0 V                        | 5.5 V            |                       |     |     | 1                       |     |      |
| I <sub>CCA</sub> + I <sub>CCB</sub> | V <sub>I</sub> = V <sub>CCI</sub> or GND,<br>I <sub>O</sub> = 0         | 1.65 V to V <sub>CCB</sub> | 2.3 V to 5.5 V   |                       |     |     | 14.4                    |     | μA   |
| C <sub>I</sub>                      | OE  | 3.3 V                      | 3.3 V            |                       |     | 2.5 | 3.5                     |     | pF   |
| C <sub>io</sub>                     | A or B port   | 3.3 V                      | 3.3 V            |                       |     | 10  |                         |     | pF   |
|                                     | A port  |                            |                  |                       |     | 5   | 6                       |     |      |
|                                     | B port  |                            |                  |                       |     | 6   | 7.5                     |     |      |

- (1) V<sub>CCI</sub> is the V<sub>CC</sub> associated with the input port.  
(2) V<sub>CCO</sub> is the V<sub>CC</sub> associated with the output port.  
(3) V<sub>CCA</sub> must be less than or equal to V<sub>CCB</sub>, and V<sub>CCA</sub> must not exceed 3.6 V.

### TIMING REQUIREMENTS

 over recommended operating free-air temperature range,  $V_{CCA} = 1.8\text{ V} \pm 0.15\text{ V}$  (unless otherwise noted)

|           |                    |                    | $V_{CCB} = 2.5\text{ V} \pm 0.2\text{ V}$ |     | $V_{CC} = 3.3\text{ V} \pm 0.3\text{ V}$ |     | $V_{CC} = 5\text{ V} \pm 0.5\text{ V}$ |     | UNIT |
|-----------|--------------------|--------------------|---|-----|--|-----|--|-----|------|
|           |                    |                    | MIN                                       | MAX | MIN                                      | MAX | MIN                                    | MAX |      |
| Data rate | Push-pull driving  |                    | 21  |     | 22                                       |     | 24                                     |     | Mbps |
|           | Open-drain driving |                    | 2   |     | 2  |     | 2                                      |     |      |
| $t_w$     | Pulse duration     | Push-pull driving  | 47  |     | 45                                       |     | 41                                     |     | ns   |
|           |                    | Open-drain driving | 500                                       |     | 500                                      |     | 500                                    |     |      |

### TIMING REQUIREMENTS

 over recommended operating free-air temperature range,  $V_{CCA} = 2.5\text{ V} \pm 0.2\text{ V}$  (unless otherwise noted)

|           |                    |                    | $V_{CCB} = 2.5\text{ V} \pm 0.2\text{ V}$ |     | $V_{CC} = 3.3\text{ V} \pm 0.3\text{ V}$ |     | $V_{CC} = 5\text{ V} \pm 0.5\text{ V}$ |     | UNIT |
|-----------|--------------------|--------------------|---|-----|--|-----|--|-----|------|
|           |                    |                    | MIN                                       | MAX | MIN                                      | MAX | MIN                                    | MAX |      |
| Data rate | Push-pull driving  |                    | 20  |     | 22                                       |     | 24                                     |     | Mbps |
|           | Open-drain driving |                    | 2   |     | 2  |     | 2                                      |     |      |
| $t_w$     | Pulse duration     | Push-pull driving  | 50  |     | 45                                       |     | 41                                     |     | ns   |
|           |                    | Open-drain driving | 500                                       |     | 500                                      |     | 500                                    |     |      |

### TIMING REQUIREMENTS

 over recommended operating free-air temperature range,  $V_{CCA} = 3.3\text{ V} \pm 0.3\text{ V}$  (unless otherwise noted)

|           |                    |                    | $V_{CC} = 3.3\text{ V} \pm 0.3\text{ V}$ |     | $V_{CC} = 5\text{ V} \pm 0.5\text{ V}$ |     | UNIT |
|-----------|--------------------|--------------------|--|-----|--|-----|------|
|           |                    |                    | MIN                                      | MAX | MIN                                    | MAX |      |
| Data rate | Push-pull driving  |                    | 23                                       |     | 24                                     |     | Mbps |
|           | Open-drain driving |                    | 2  |     | 2                                      |     |      |
| $t_w$     | Pulse duration     | Push-pull driving  | 43                                       |     | 41                                     |     | ns   |
|           |                    | Open-drain driving | 500                                      |     | 500                                    |     |      |

## SWITCHING CHARACTERISTICS

over recommended operating free-air temperature range,  $V_{CCA} = 1.8 \text{ V} \pm 0.15 \text{ V}$  (unless otherwise noted)

| PARAMETER     | FROM<br>(INPUT)         | TO<br>(OUTPUT) | TEST CONDITIONS    | $V_{CCB} = 2.5 \text{ V} \pm 0.2 \text{ V}$ |      | $V_{CCB} = 3.3 \text{ V} \pm 0.3 \text{ V}$ |      | $V_{CCB} = 5 \text{ V} \pm 0.5 \text{ V}$ |      | UNIT |
|---------------|-------------------------|----------------|--------------------|---|------|---|------|---|------|------|
|               |                         |                |                    | MIN   | MAX  | MIN   | MAX  | MIN                                       | MAX  |      |
| $t_{PHL}$     | A                       | B              | Push-pull driving  |   | 5.3  |   | 5.4  |   | 6.8  | ns   |
|               |                         |                | Open-drain driving | 2.3   | 8.8  | 2.4   | 9.6  | 2.6                                       | 10   |      |
| $t_{PLH}$     |                         |                | Push-pull driving  |   | 6.8  |   | 7.1  |   | 7.5  |      |
|               |                         |                | Open-drain driving | 45  | 260  | 36  | 208  | 27  | 198  |      |
| $t_{PHL}$     | B                       | A              | Push-pull driving  |   | 4.4  |   | 4.5  |   | 4.7  | ns   |
|               |                         |                | Open-drain driving | 1.9   | 5.3  | 1.1   | 4.4  | 1.2                                       | 4    |      |
| $t_{PLH}$     |                         |                | Push-pull driving  |   | 5.3  |   | 4.5  |   | 0.5  |      |
|               |                         |                | Open-drain driving | 45  | 175  | 36  | 140  | 27  | 102  |      |
| $t_{en}$      | OE                      | A or B         |                    |   | 200  |   | 200  |   | 200  | ns   |
| $t_{dis}$     | OE                      | A or B         |                    |   | 50   |   | 40   |   | 35   | ns   |
| $t_{rA}$      | A-port rise time        |                | Push-pull driving  | 3.2   | 9.5  | 2.3   | 9.3  | 2   | 7.6  | ns   |
|               |                         |                | Open-drain driving | 38  | 165  | 30  | 132  | 22  | 95   |      |
| $t_{rB}$      | B-port rise time        |                | Push-pull driving  | 4   | 10.8 | 2.7   | 9.1  | 2.7                                       | 7.6  | ns   |
|               |                         |                | Open-drain driving | 34  | 145  | 23  | 106  | 10  | 58   |      |
| $t_{fA}$      | A-port fall time        |                | Push-pull driving  | 2   | 5.9  | 1.9   | 6    | 1.7                                       | 13.3 | ns   |
|               |                         |                | Open-drain driving | 4.4   | 6.9  | 4.3   | 6.4  | 4.2                                       | 6.1  |      |
| $t_{fB}$      | B-port fall time        |                | Push-pull driving  | 2.9   | 13.8 | 2.8   | 16.2 | 2.8                                       | 16.2 | ns   |
|               |                         |                | Open-drain driving | 6.9   | 13.8 | 7.5   | 16.2 | 7   | 16.2 |      |
| $t_{SK(O)}$   | Channel-to-channel skew |                |                    |   | 0.7  |   | 0.7  |   | 0.7  | ns   |
| Max data rate |                         |                | Push-pull driving  |   |      |   | 22   |   | 24   | Mbps |
|               |                         |                | Open-drain driving |   |      |   | 2    |   | 2    |      |

## SWITCHING CHARACTERISTICS

 over recommended operating free-air temperature range,  $V_{CCA} = 2.5\text{ V} \pm 0.2\text{ V}$  (unless otherwise noted)

| PARAMETER     | FROM<br>(INPUT)         | TO<br>(OUTPUT) | TEST CONDITIONS    | $V_{CCB} = 2.5\text{ V} \pm 0.2\text{ V}$ |     | $V_{CCB} = 3.3\text{ V} \pm 0.3\text{ V}$ |     | $V_{CCB} = 5\text{ V} \pm 0.5\text{ V}$ |      | UNIT |
|---------------|-------------------------|----------------|--------------------|---|-----|---|-----|---|------|------|
|               |                         |                |                    | MIN                                       | MAX | MIN                                       | MAX | MIN                                     | MAX  |      |
| $t_{PHL}$     | A                       | B              | Push-pull driving  | 3.2                                       |     | 3.7                                       |     | 3.8                                     |      | ns   |
|               |                         |                | Open-drain driving | 1.7                                       | 6.3 | 2   | 6   | 2.1                                     | 5.8  |      |
| $t_{PLH}$     |                         |                | Push-pull driving  | 3.5                                       |     | 4.1                                       |     | 4.4                                     |      |      |
|               |                         |                | Open-drain driving | 43  | 250 | 36  | 206 | 27                                      | 190  |      |
| $t_{PHL}$     | B                       | A              | Push-pull driving  | 3   |     | 3.6                                       |     | 4.3                                     |      | ns   |
|               |                         |                | Open-drain driving | 1.8                                       | 4.7 | 2.6                                       | 4.2 | 1.2                                     | 4    |      |
| $t_{PLH}$     |                         |                | Push-pull driving  | 2.5                                       |     | 1.6                                       |     | 1                                       |      |      |
|               |                         |                | Open-drain driving | 44  | 170 | 37  | 140 | 27                                      | 103  |      |
| $t_{en}$      | OE                      | A or B         |                    | 200                                       |     | 200                                       |     | 200                                     |      | ns   |
| $t_{dis}$     | OE                      | A or B         |                    | 50  |     | 40  |     | 35                                      |      | ns   |
| $t_{rA}$      | A-port rise time        |                | Push-pull driving  | 2.8                                       | 7.4 | 2.6                                       | 6.6 | 1.8                                     | 5.6  | ns   |
|               |                         |                | Open-drain driving | 34  | 149 | 28  | 121 | 24                                      | 89   |      |
| $t_{rB}$      | B-port rise time        |                | Push-pull driving  | 3.2                                       | 8.3 | 2.9                                       | 7.2 | 2.4                                     | 6.1  | ns   |
|               |                         |                | Open-drain driving | 35  | 151 | 24  | 112 | 12                                      | 64   |      |
| $t_{fA}$      | A-port fall time        |                | Push-pull driving  | 1.9                                       | 5.7 | 1.9                                       | 5.5 | 1.8                                     | 5.3  | ns   |
|               |                         |                | Open-drain driving | 4.4                                       | 6.9 | 4.3                                       | 6.2 | 4.2                                     | 5.8  |      |
| $t_{fB}$      | B-port fall time        |                | Push-pull driving  | 2.2                                       | 7.8 | 2.4                                       | 6.7 | 2.6                                     | 6.6  | ns   |
|               |                         |                | Open-drain driving | 5.1                                       | 8.8 | 5.4                                       | 9.4 | 5.4                                     | 10.4 |      |
| $t_{SK(O)}$   | Channel-to-channel skew |                |                    | 0.7                                       |     | 0.7                                       |     | 0.7                                     |      | ns   |
| Max data rate |                         |                | Push-pull driving  | 20  |     | 22  |     | 24                                      |      | Mbps |
|               |                         |                | Open-drain driving | 2   |     | 2   |     | 2                                       |      |      |

## SWITCHING CHARACTERISTICS

over recommended operating free-air temperature range,  $V_{CCA} = 3.3 \text{ V} \pm 0.3 \text{ V}$  (unless otherwise noted)

| PARAMETER     | FROM<br>(INPUT)         | TO<br>(OUTPUT) | TEST CONDITIONS    | $V_{CCB} = 3.3 \text{ V} \pm 0.3 \text{ V}$ |     | $V_{CCB} = 5 \text{ V} \pm 0.5 \text{ V}$ |     | UNIT |
|---------------|-------------------------|----------------|--------------------|---|-----|---|-----|------|
|               |                         |                |                    | MIN   | MAX | MIN                                       | MAX |      |
| $t_{PHL}$     | A                       | B              | Push-pull driving  |   | 2.4 |   | 3.1 | ns   |
|               |                         |                | Open-drain driving | 1.3   | 4.2 | 1.4                                       | 4.6 |      |
| $t_{PLH}$     |                         |                | Push-pull driving  |   | 4.2 |   | 4.4 |      |
|               |                         |                | Open-drain driving | 36  | 204 | 28  | 165 |      |
| $t_{PHL}$     | B                       | A              | Push-pull driving  |   | 2.5 |   | 3.3 | ns   |
|               |                         |                | Open-drain driving | 1   | 124 | 1   | 97  |      |
| $t_{PLH}$     |                         |                | Push-pull driving  |   | 2.5 |   | 2.6 |      |
|               |                         |                | Open-drain driving | 3   | 139 | 3   | 105 |      |
| $t_{en}$      | OE                      | A or B         |                    | 200   |     | 200                                       | ns  |      |
| $t_{dis}$     | OE                      | A or B         |                    | 40  |     | 35  | ns  |      |
| $t_{rA}$      | A-port rise time        |                | Push-pull driving  | 2.3   | 5.6 | 1.9                                       | 4.8 | ns   |
|               |                         |                | Open-drain driving | 25  | 116 | 19  | 85  |      |
| $t_{rB}$      | B-port rise time        |                | Push-pull driving  | 2.5   | 6.4 | 2.1                                       | 7.4 | ns   |
|               |                         |                | Open-drain driving | 26  | 116 | 14  | 72  |      |
| $t_{fA}$      | A-port fall time        |                | Push-pull driving  | 2   | 5.4 | 1.9                                       | 5   | ns   |
|               |                         |                | Open-drain driving | 4.3   | 6.1 | 4.2                                       | 5.7 |      |
| $t_{fB}$      | B-port fall time        |                | Push-pull driving  | 2.3   | 7.4 | 2.4                                       | 7.6 | ns   |
|               |                         |                | Open-drain driving | 5   | 7.6 | 4.8                                       | 8.3 |      |
| $t_{SK(O)}$   | Channel-to-channel skew |                |                    | 0.7   |     | 0.7                                       | ns  |      |
| Max data rate |                         |                | Push-pull driving  | 23  |     | 24  |     | Mbps |
|               |                         |                | Open-drain driving | 2   |     | 2   |     |      |



## PRINCIPLES OF OPERATION

### Application Notes

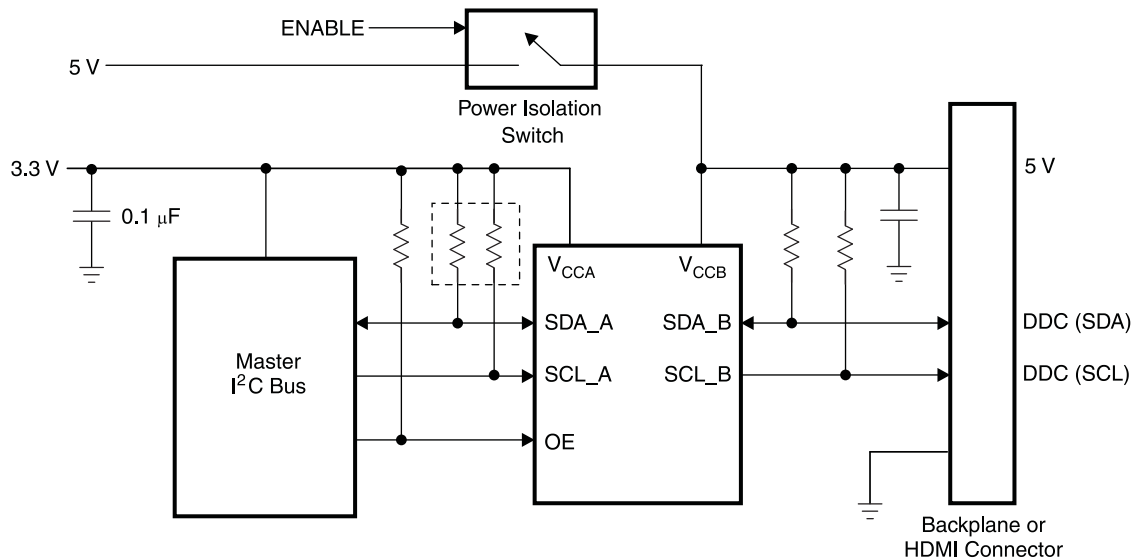

Figure 1. Typical Design Example

The TCA9406 has a  $V_{CC}$  isolation feature known as  $I_{off}$  partial power down and backdrive protection. If a cable is connected, and the connected external system is still powered on, the system can be put into standby mode by shutting down the power rail. In this state, the TCA9406 has a leakage current of approximately  $2 \mu A$  caused by current flow from powered-on system.

### Power Up, Power Down

One advantage of the TCA9406 translator is that either power supply can be ramped up first. Another advantage is that either power supply can be set to 0 V, and the outputs are in high-impedance state.

The recommended power up sequence is:

1. Apply power to the first  $V_{CC}$  and apply the second  $V_{CC}$
2. Drive the OE input high to enable the device

The recommended power down sequence is:

1. Drive OE input low to disable the device
2. Switch Off the power from either  $V_{CC}$  and remove power from other  $V_{CC}$ .

### Enable/Disable

The TCA9406 has an OE input that is used to disable the device by setting OE low, which place all I/Os in the high-impedance state. The control OE is referenced to the  $V_{CCA}$  supply. A pull-down resistor tying OE to ground should be used to ensure that bus contention, excessive currents, or oscillations do not occur during power up and power down. The value of resistor is based upon the current sinking capability of the device.

### Integrated Pullup Resistors on the I/Os (A-Ports/B-Ports)

Each A-port I/O has an internal 10-k $\Omega$  pullup resistor to  $V_{CCA}$ , and each B-port I/O has an internal 10-k $\Omega$  pullup resistor to  $V_{CCB}$ . If a smaller value of pullup resistor is required, an external resistor must be added from the I/O to  $V_{CCA}$  or  $V_{CCB}$  (in parallel with the internal 10-k $\Omega$  resistors). Adding lower value pull-up resistors may effect  $V_{OL}$  levels. The internal pullups of the TCA9406 are disabled when the OE pin is low.

## PARAMETER MEASUREMENT INFORMATION

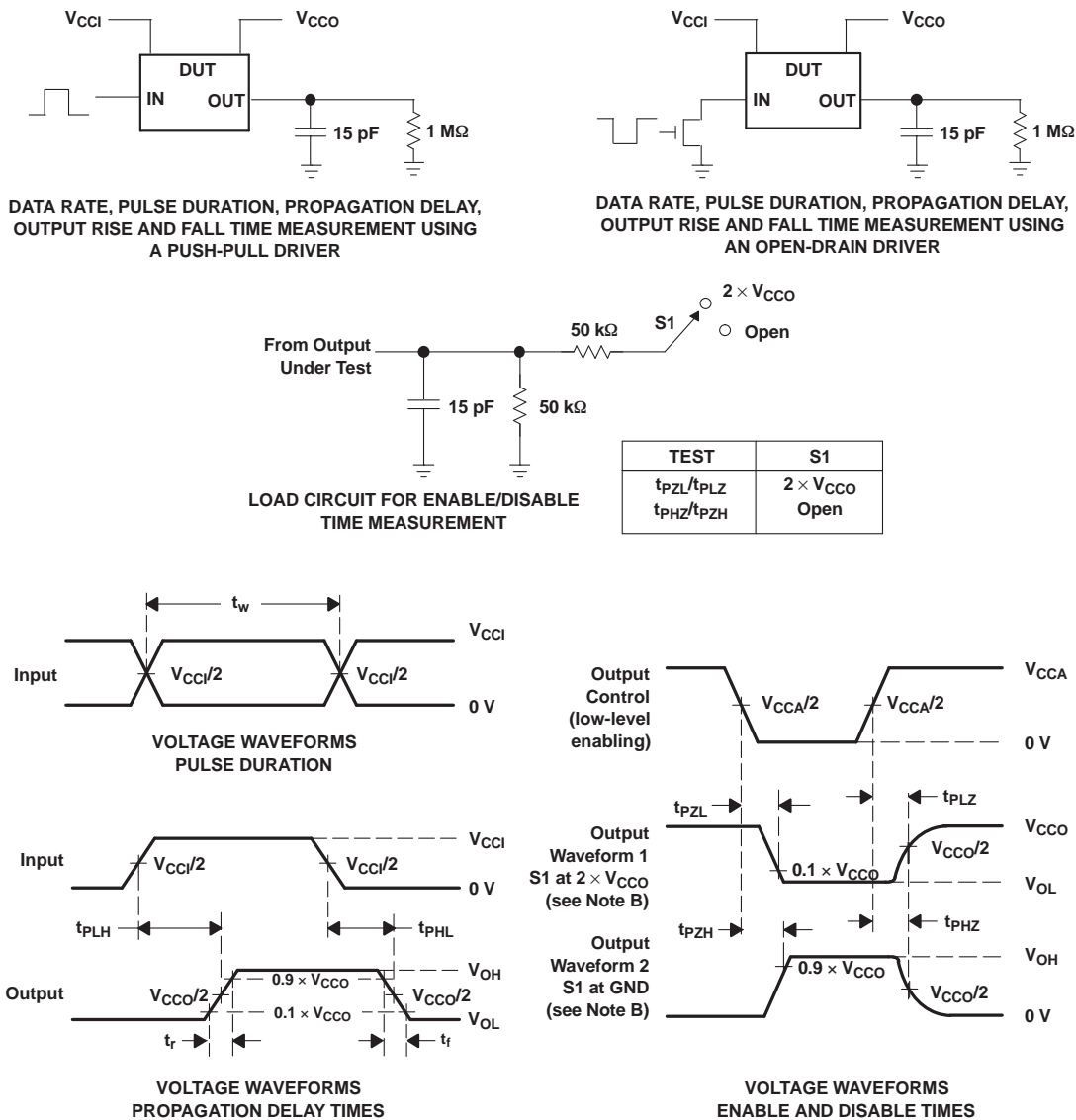

- $C_L$  includes probe and jig capacitance.
- Waveform 1 is for an output with internal conditions such that the output is low, except when disabled by the output control. Waveform 2 is for an output with internal conditions such that the output is high, except when disabled by the output control.
- All input pulses are supplied by generators having the following characteristics:  $PRR \leq 10$  MHz,  $Z_O = 50 \Omega$ ,  $dv/dt \geq 1$  V/ns.
- The outputs are measured one at a time, with one transition per measurement.
- $t_{PLZ}$  and  $t_{PHZ}$  are the same as  $t_{dis}$ .
- $t_{PZL}$  and  $t_{PZH}$  are the same as  $t_{en}$ .
- $t_{PLH}$  and  $t_{PHL}$  are the same as  $t_{pd}$ .
- $V_{CCI}$  is the  $V_{CC}$  associated with the input port.
- $V_{CCO}$  is the  $V_{CC}$  associated with the output port.
- All parameters and waveforms are not applicable to all devices.

**Figure 2. Load Circuit and Voltage Waveforms**

---

| <b>Changes from Revision A (February 2013) to Revision B</b>               | <b>Page</b>       |
|--|-------------------|
| • Removed ordering information table, information now located in POA. .... | <a href="#">2</a> |

---

## PACKAGING INFORMATION

| Orderable Device | Status<br>(1) | Package Type | Package Drawing | Pins | Package Qty | Eco Plan<br>(2)         | Lead/Ball Finish | MSL Peak Temp<br>(3) | Op Temp (°C) | Device Marking<br>(4/5) | Samples                 |
|------------------|---------------|--------------|-----------------|------|-------------|-------------------------|------------------|----------------------|--------------|-------------------------|-------------------------|
| HPA02270YZPR     | ACTIVE        | DSBGA        | YZP             | 8    | 3000        | Green (RoHS & no Sb/Br) | SNAGCU           | Level-1-260C-UNLIM   | -40 to 85    | 7W                      | <a href="#">Samples</a> |
| TCA9406DCTR      | ACTIVE        | SM8          | DCT             | 8    | 3000        | Green (RoHS & no Sb/Br) | CU NIPDAU        | Level-1-260C-UNLIM   | -40 to 85    | NF9<br>Z                | <a href="#">Samples</a> |
| TCA9406DCUR      | ACTIVE        | US8          | DCU             | 8    | 3000        | Green (RoHS & no Sb/Br) | CU NIPDAU        | Level-1-260C-UNLIM   | -40 to 85    | NF9R                    | <a href="#">Samples</a> |
| TCA9406YZPR      | ACTIVE        | DSBGA        | YZP             | 8    | 3000        | Green (RoHS & no Sb/Br) | SNAGCU           | Level-1-260C-UNLIM   | -40 to 85    | 7W                      | <a href="#">Samples</a> |

(1) The marketing status values are defined as follows:

**ACTIVE:** Product device recommended for new designs.

**LIFEBUY:** TI has announced that the device will be discontinued, and a lifetime-buy period is in effect.

**NRND:** Not recommended for new designs. Device is in production to support existing customers, but TI does not recommend using this part in a new design.

**PREVIEW:** Device has been announced but is not in production. Samples may or may not be available.

**OBSELETE:** TI has discontinued the production of the device.

(2) Eco Plan - The planned eco-friendly classification: Pb-Free (RoHS), Pb-Free (RoHS Exempt), or Green (RoHS & no Sb/Br) - please check <http://www.ti.com/productcontent> for the latest availability information and additional product content details.

**TBD:** The Pb-Free/Green conversion plan has not been defined.

**Pb-Free (RoHS):** TI's terms "Lead-Free" or "Pb-Free" mean semiconductor products that are compatible with the current RoHS requirements for all 6 substances, including the requirement that lead not exceed 0.1% by weight in homogeneous materials. Where designed to be soldered at high temperatures, TI Pb-Free products are suitable for use in specified lead-free processes.

**Pb-Free (RoHS Exempt):** This component has a RoHS exemption for either 1) lead-based flip-chip solder bumps used between the die and package, or 2) lead-based die adhesive used between the die and leadframe. The component is otherwise considered Pb-Free (RoHS compatible) as defined above.

**Green (RoHS & no Sb/Br):** TI defines "Green" to mean Pb-Free (RoHS compatible), and free of Bromine (Br) and Antimony (Sb) based flame retardants (Br or Sb do not exceed 0.1% by weight in homogeneous material)

(3) MSL, Peak Temp. -- The Moisture Sensitivity Level rating according to the JEDEC industry standard classifications, and peak solder temperature.

(4) There may be additional marking, which relates to the logo, the lot trace code information, or the environmental category on the device.

(5) Multiple Device Markings will be inside parentheses. Only one Device Marking contained in parentheses and separated by a "~" will appear on a device. If a line is indented then it is a continuation of the previous line and the two combined represent the entire Device Marking for that device.

**Important Information and Disclaimer:** The information provided on this page represents TI's knowledge and belief as of the date that it is provided. TI bases its knowledge and belief on information provided by third parties, and makes no representation or warranty as to the accuracy of such information. Efforts are underway to better integrate information from third parties. TI has taken and

continues to take reasonable steps to provide representative and accurate information but may not have conducted destructive testing or chemical analysis on incoming materials and chemicals. TI and TI suppliers consider certain information to be proprietary, and thus CAS numbers and other limited information may not be available for release.

In no event shall TI's liability arising out of such information exceed the total purchase price of the TI part(s) at issue in this document sold by TI to Customer on an annual basis.

**TAPE AND REEL INFORMATION**

**QUADRANT ASSIGNMENTS FOR PIN 1 ORIENTATION IN TAPE**

\*All dimensions are nominal

| Device      | Package Type | Package Drawing | Pins | SPQ  | Reel Diameter (mm) | Reel Width W1 (mm) | A0 (mm) | B0 (mm) | K0 (mm) | P1 (mm) | W (mm) | Pin1 Quadrant |
|-------------|--------------|-----------------|------|------|--------------------|--------------------|---------|---------|---------|---------|--------|---------------|
| TCA9406DCTR | SM8          | DCT             | 8    | 3000 | 180.0              | 13.0               | 3.35    | 4.5     | 1.55    | 4.0     | 12.0   | Q3            |
| TCA9406DCUR | US8          | DCU             | 8    | 3000 | 180.0              | 8.4                | 2.25    | 3.35    | 1.05    | 4.0     | 8.0    | Q3            |
| TCA9406YZPR | DSBGA        | YZP             | 8    | 3000 | 180.0              | 8.4                | 1.11    | 2.1     | 0.56    | 4.0     | 8.0    | Q1            |

**TAPE AND REEL BOX DIMENSIONS**

\*All dimensions are nominal

| Device      | Package Type | Package Drawing | Pins | SPQ  | Length (mm) | Width (mm) | Height (mm) |
|-------------|--------------|-----------------|------|------|-------------|------------|-------------|
| TCA9406DCTR | SM8          | DCT             | 8    | 3000 | 182.0       | 182.0      | 20.0        |
| TCA9406DCUR | US8          | DCU             | 8    | 3000 | 202.0       | 201.0      | 28.0        |
| TCA9406YZPR | DSBGA        | YZP             | 8    | 3000 | 210.0       | 185.0      | 35.0        |

DCT (R-PDSO-G8)

PLASTIC SMALL-OUTLINE PACKAGE

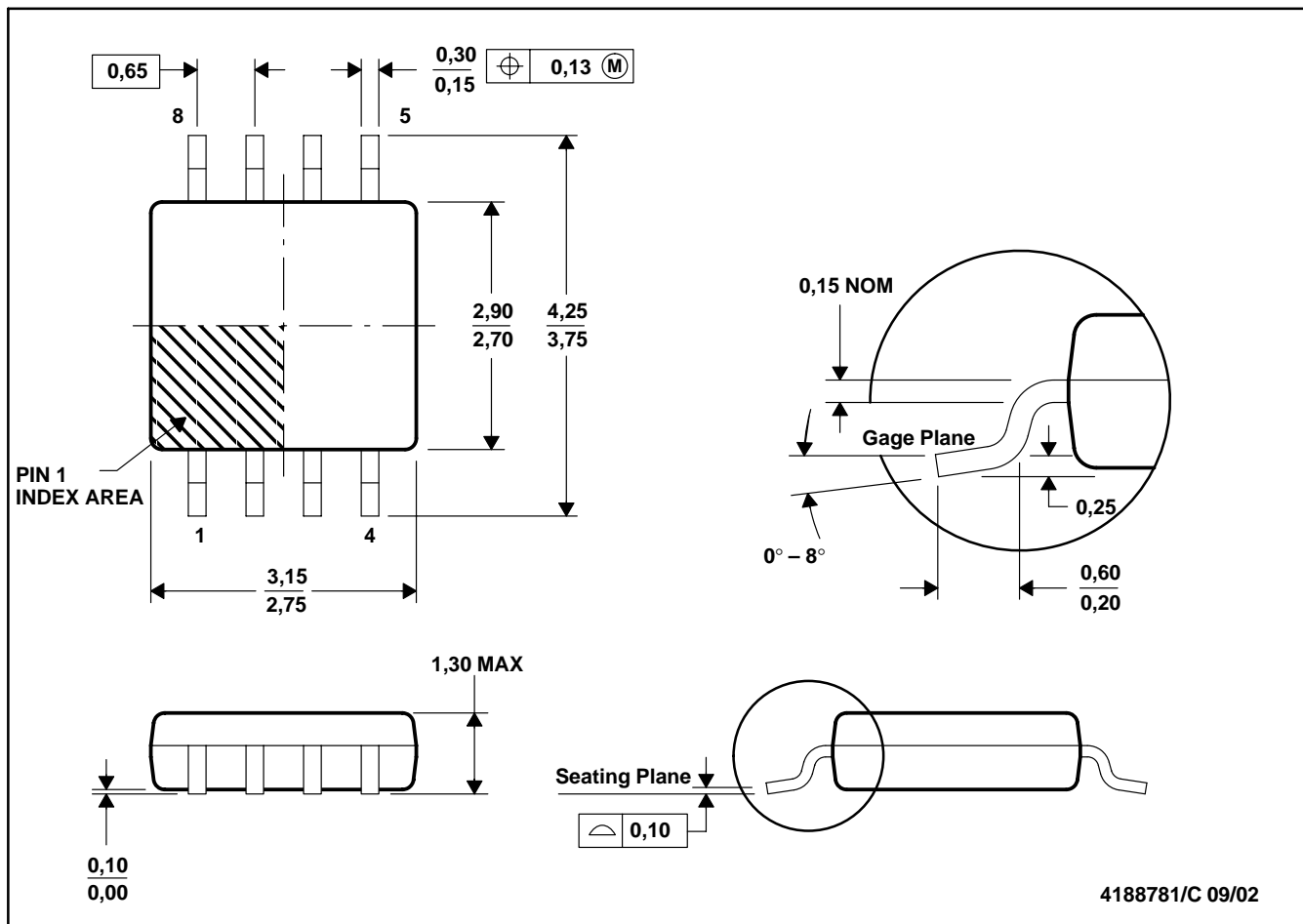

4188781/C 09/02

- NOTES: A. All linear dimensions are in millimeters.  
 B. This drawing is subject to change without notice.  
 C. Body dimensions do not include mold flash or protrusion  
 D. Falls within JEDEC MO-187 variation DA.



DCT (R-PDSO-G8)

PLASTIC SMALL OUTLINE



- NOTES:
- A. All linear dimensions are in millimeters.
  - B. This drawing is subject to change without notice.
  - C. Publication IPC-7351 is recommended for alternate designs.
  - D. Laser cutting apertures with trapezoidal walls and also rounding corners will offer better paste release. Customers should contact their board assembly site for stencil design recommendations. Refer to IPC-7525.
  - E. Customers should contact their board fabrication site for solder mask tolerances between and around signal pads.

DCU (R-PDSO-G8)

PLASTIC SMALL-OUTLINE PACKAGE (DIE DOWN)

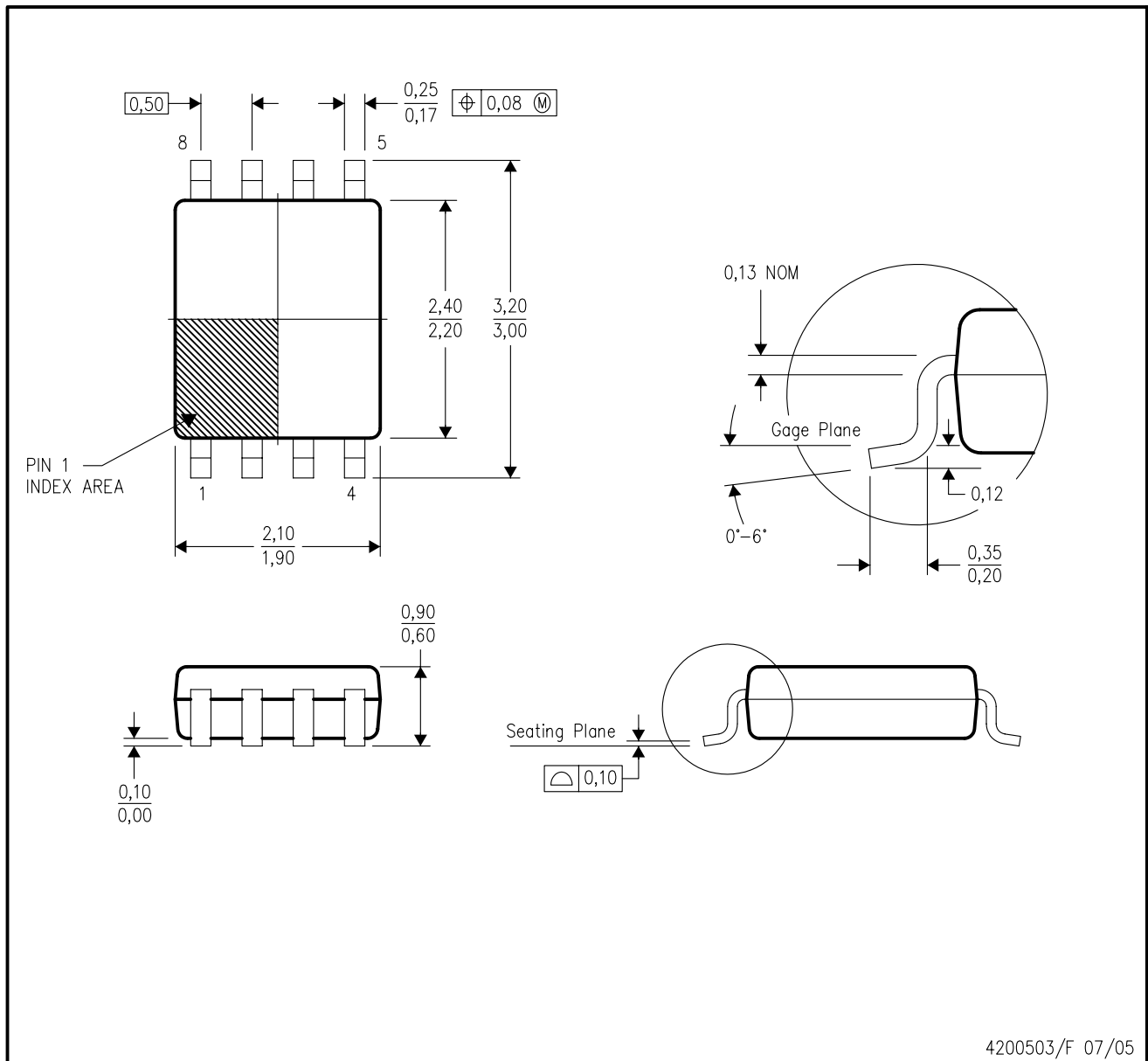

- NOTES:
- A. All linear dimensions are in millimeters.
  - B. This drawing is subject to change without notice.
  - C. Body dimensions do not include mold flash or protrusion. Mold flash and protrusion shall not exceed 0.15 per side.
  - D. Falls within JEDEC MO-187 variation CA.

DCU (S-PDSO-G8)

PLASTIC SMALL OUTLINE PACKAGE (DIE DOWN)



- NOTES:
- A. All linear dimensions are in millimeters.
  - B. This drawing is subject to change without notice.
  - C. Publication IPC-7351 is recommended for alternate designs.
  - D. Laser cutting apertures with trapezoidal walls and also rounding corners will offer better paste release. Customers should contact their board assembly site for stencil design recommendations. Refer to IPC-7525 for other stencil recommendations.
  - E. Customers should contact their board fabrication site for solder mask tolerances between and around signal pads.

YZP (R-XBGA-N8)

DIE-SIZE BALL GRID ARRAY

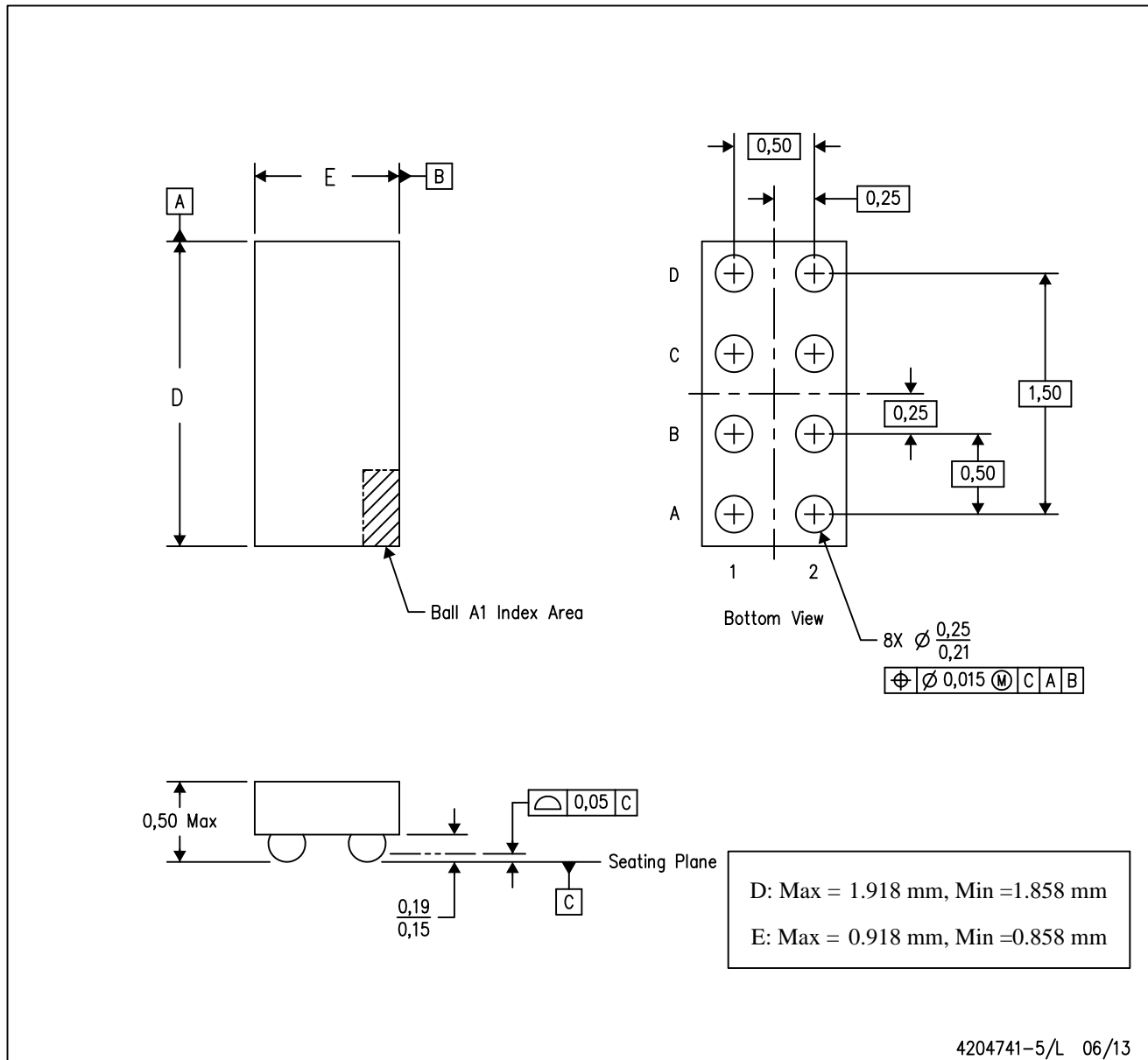

- NOTES:
- A. All linear dimensions are in millimeters. Dimensioning and tolerancing per ASME Y14.5M-1994.
  - B. This drawing is subject to change without notice.
  - C. NanoFree™ package configuration.

NanoFree is a trademark of Texas Instruments.

## IMPORTANT NOTICE

Texas Instruments Incorporated and its subsidiaries (TI) reserve the right to make corrections, enhancements, improvements and other changes to its semiconductor products and services per JESD46, latest issue, and to discontinue any product or service per JESD48, latest issue. Buyers should obtain the latest relevant information before placing orders and should verify that such information is current and complete. All semiconductor products (also referred to herein as "components") are sold subject to TI's terms and conditions of sale supplied at the time of order acknowledgment.

TI warrants performance of its components to the specifications applicable at the time of sale, in accordance with the warranty in TI's terms and conditions of sale of semiconductor products. Testing and other quality control techniques are used to the extent TI deems necessary to support this warranty. Except where mandated by applicable law, testing of all parameters of each component is not necessarily performed.

TI assumes no liability for applications assistance or the design of Buyers' products. Buyers are responsible for their products and applications using TI components. To minimize the risks associated with Buyers' products and applications, Buyers should provide adequate design and operating safeguards.

TI does not warrant or represent that any license, either express or implied, is granted under any patent right, copyright, mask work right, or other intellectual property right relating to any combination, machine, or process in which TI components or services are used. Information published by TI regarding third-party products or services does not constitute a license to use such products or services or a warranty or endorsement thereof. Use of such information may require a license from a third party under the patents or other intellectual property of the third party, or a license from TI under the patents or other intellectual property of TI.

Reproduction of significant portions of TI information in TI data books or data sheets is permissible only if reproduction is without alteration and is accompanied by all associated warranties, conditions, limitations, and notices. TI is not responsible or liable for such altered documentation. Information of third parties may be subject to additional restrictions.

Resale of TI components or services with statements different from or beyond the parameters stated by TI for that component or service voids all express and any implied warranties for the associated TI component or service and is an unfair and deceptive business practice. TI is not responsible or liable for any such statements.

Buyer acknowledges and agrees that it is solely responsible for compliance with all legal, regulatory and safety-related requirements concerning its products, and any use of TI components in its applications, notwithstanding any applications-related information or support that may be provided by TI. Buyer represents and agrees that it has all the necessary expertise to create and implement safeguards which anticipate dangerous consequences of failures, monitor failures and their consequences, lessen the likelihood of failures that might cause harm and take appropriate remedial actions. Buyer will fully indemnify TI and its representatives against any damages arising out of the use of any TI components in safety-critical applications.

In some cases, TI components may be promoted specifically to facilitate safety-related applications. With such components, TI's goal is to help enable customers to design and create their own end-product solutions that meet applicable functional safety standards and requirements. Nonetheless, such components are subject to these terms.

No TI components are authorized for use in FDA Class III (or similar life-critical medical equipment) unless authorized officers of the parties have executed a special agreement specifically governing such use.

Only those TI components which TI has specifically designated as military grade or "enhanced plastic" are designed and intended for use in military/aerospace applications or environments. Buyer acknowledges and agrees that any military or aerospace use of TI components which have **not** been so designated is solely at the Buyer's risk, and that Buyer is solely responsible for compliance with all legal and regulatory requirements in connection with such use.

TI has specifically designated certain components as meeting ISO/TS16949 requirements, mainly for automotive use. In any case of use of non-designated products, TI will not be responsible for any failure to meet ISO/TS16949.

### Products

|                              |  |
|------------------------------|--|
| Audio                        | <a href="http://www.ti.com/audio">www.ti.com/audio</a>                               |
| Amplifiers                   | <a href="http://amplifier.ti.com">amplifier.ti.com</a>                               |
| Data Converters              | <a href="http://dataconverter.ti.com">dataconverter.ti.com</a>                       |
| DLP® Products                | <a href="http://www.dlp.com">www.dlp.com</a>   |
| DSP                          | <a href="http://dsp.ti.com">dsp.ti.com</a>   |
| Clocks and Timers            | <a href="http://www.ti.com/clocks">www.ti.com/clocks</a>                             |
| Interface                    | <a href="http://interface.ti.com">interface.ti.com</a>                               |
| Logic                        | <a href="http://logic.ti.com">logic.ti.com</a>                                       |
| Power Mgmt                   | <a href="http://power.ti.com">power.ti.com</a>                                       |
| Microcontrollers             | <a href="http://microcontroller.ti.com">microcontroller.ti.com</a>                   |
| RFID                         | <a href="http://www.ti-rfid.com">www.ti-rfid.com</a>                                 |
| OMAP Applications Processors | <a href="http://www.ti.com/omap">www.ti.com/omap</a>                                 |
| Wireless Connectivity        | <a href="http://www.ti.com/wirelessconnectivity">www.ti.com/wirelessconnectivity</a> |

### Applications

|                               |  |
|-------------------------------|--|
| Automotive and Transportation | <a href="http://www.ti.com/automotive">www.ti.com/automotive</a>                         |
| Communications and Telecom    | <a href="http://www.ti.com/communications">www.ti.com/communications</a>                 |
| Computers and Peripherals     | <a href="http://www.ti.com/computers">www.ti.com/computers</a>                           |
| Consumer Electronics          | <a href="http://www.ti.com/consumer-apps">www.ti.com/consumer-apps</a>                   |
| Energy and Lighting           | <a href="http://www.ti.com/energy">www.ti.com/energy</a>                                 |
| Industrial                    | <a href="http://www.ti.com/industrial">www.ti.com/industrial</a>                         |
| Medical                       | <a href="http://www.ti.com/medical">www.ti.com/medical</a>                               |
| Security                      | <a href="http://www.ti.com/security">www.ti.com/security</a>                             |
| Space, Avionics and Defense   | <a href="http://www.ti.com/space-avionics-defense">www.ti.com/space-avionics-defense</a> |
| Video and Imaging             | <a href="http://www.ti.com/video">www.ti.com/video</a>                                   |

### TI E2E Community

[e2e.ti.com](http://e2e.ti.com)